

GT-01 Access system



Customer loyalty and increased sales with GT-01

Discover the GT-01 from Goetz Ticket, a versatile solution for retaining customers and increasing sales. This innovative system not only enables the efficient regulation of access to sanitary facilities and other paid areas, but also offers operators triple benefits:

- 1. Additional income:** The fees that guests pay at the ticket machine can be used to cover the cleaning costs for the sanitary facilities.
- 2. Increased sales due to the optional payback coupon system:** Thanks to optional coupons, visitors are encouraged to make purchases in other departments such as restaurants or shops, which increases overall sales.
- 3. Valuable analysis and evaluation functions:** Available analysis options provide important information to optimise workflows and cost management.

The space-saving design adapts seamlessly to different spatial situations, while the stainless steel body and robust plastic housing ensure durability. With colour options such as yellow, grey, blue and other colours on request, the system blends harmoniously into any environment. Thanks to numerous customisation options such as coin change function, ticket printing and programmable display, individual customer requirements can be easily met.

GT-01 is used in various sectors such as:

- Gastronomy
- Petrol stations
- Public restrooms
- Sightseeing
- Shopping malls
- Locations where efficient billing and access control is required

The advantages of the system at one glance:

- **Optimisation of cleaning costs:**
The cleaning costs for sanitary facilities can be covered through the efficient utilisation of income.
- **Increased sales with payback coupon system:**
Incentives for guests to shop in other departments lead to an increase in overall sales.
- **Optimisation of business processes through evaluation functions:**
Valuable data analyses enable targeted optimisation of work processes and cost management.
- **Simple user guidance due to ergonomic design:**
Intuitive interface for smooth operation.
- **Space-saving and slim design:**
Adapts itself flexibly to various spatial situations and optimises the available space.
- **Additional escape path with folding uprights and automatic refitting function:**
An innovative safety feature for even more versatility and reliability in emergency situations.

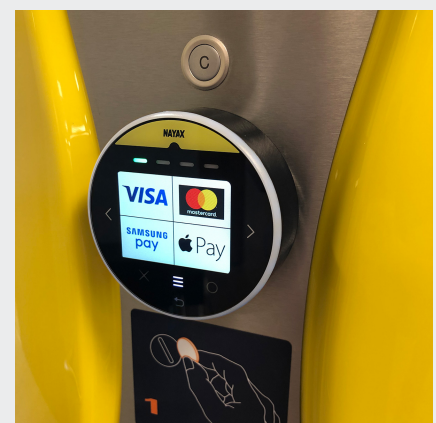

Additional cashless payment terminal

Dimensions

Overall height	1720 mm
Overall width	902 mm
Passage width	532 mm

Visible surfaces

- Stainless steel satin finish
- Housing for access system: Plastic yellow, grey, blue or other colours on request

Function

1. The customer pays the specified price at the access system
2. The turnstile clears the way
3. Leaving the area: The turnstile is free in the exit direction

Option Payback-Coupon-System

- A payback coupon is issued after payment
- If the guest consumes something in the gastronomic area, the fee paid can be offset when the payback voucher is presented

Assembly

- On ready-made floor, pallet or substructure

Electronics

Control integrated in the system
Supply: 110-230 VAC 50/60 Hz

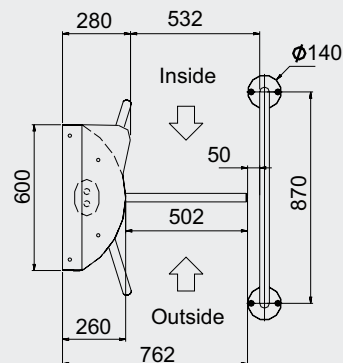
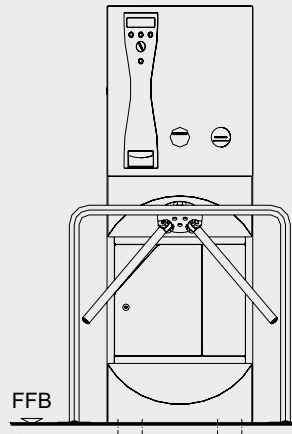
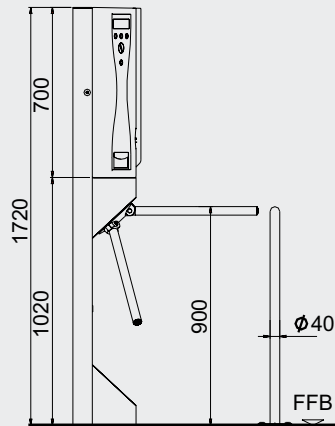

Götz Ticket GmbH
Victoria Boulevard B 109
77836 Rheinmünster
Germany

Fon +49 (0) 7229 18 51 18-0
E-Mail info@goetzticket.de
Website www.goetzticket.de

